

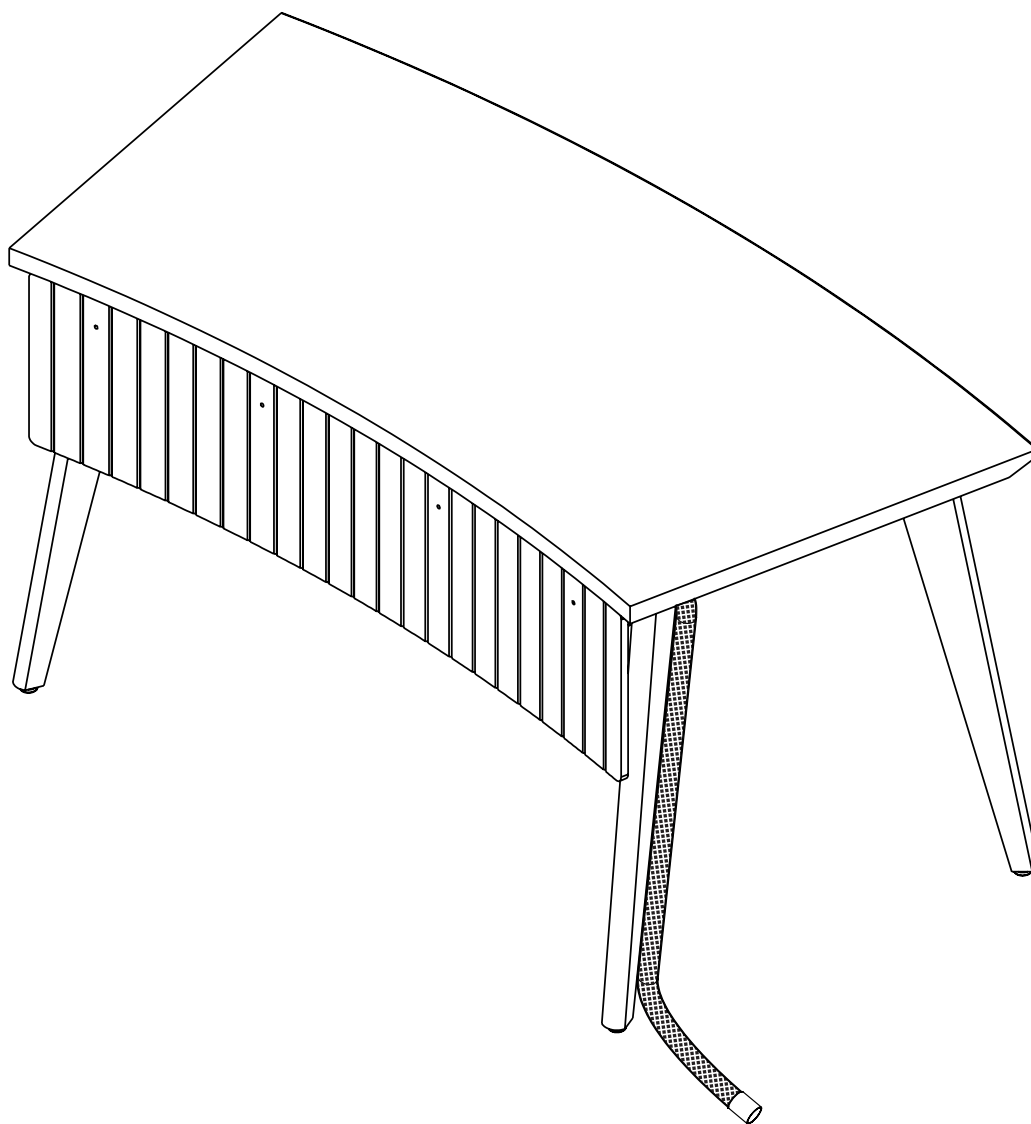

5' Arc™ Meeting Table (2 Person)

AT/2P/G2



PARTS

ID	QTY	PART NUMBER	DESCRIPTION
	(1)	205-6030	ARC Table Top Segment
A	(4)	302-355	8-32 x 1/2" Binder Post Modesty Panel Fastener
B	(4)	300-485	1/4-20 x 1/2" Cable Raceway Mounting Screw
C	(24)	300-585	1/4-20 x 3/4" Leg Mounting Screw
D	(1)	P-305-590/BO/CM	Table Leg with Wireloom
E	(3)	P-305-590	Table Leg
F	(2)	305-585	Cable Raceway
G	(1)	204-320	Modesty Panel



302-355
8-32 x 1/2"
Modesty Panel Fastener

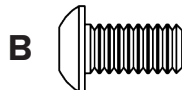

300-485
1/4-20 x 1/2"
Cable Raceway
Mounting Screw

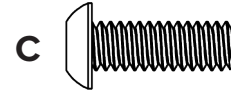

300-585
1/4-20 x 3/4"
Leg Mounting Screw

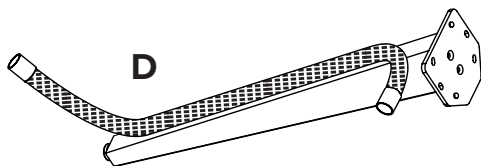

P-305-590/BO/CM
Table Leg with
Wireloom

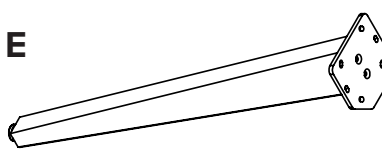

P-305-590
Table Leg

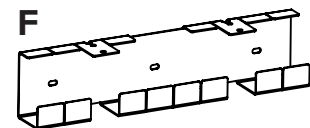

305-585
Cable Raceway

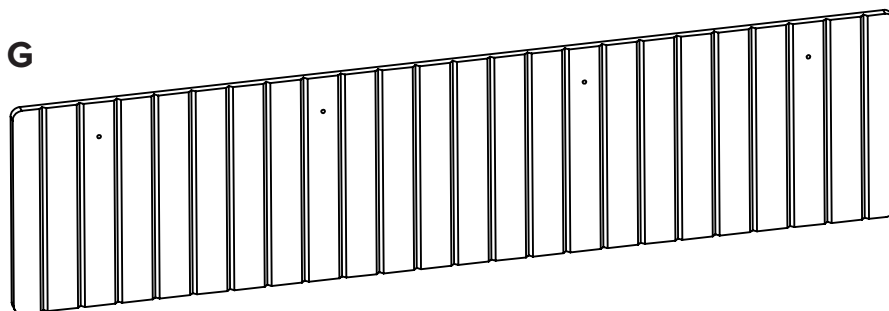

204-320
Modesty Panel

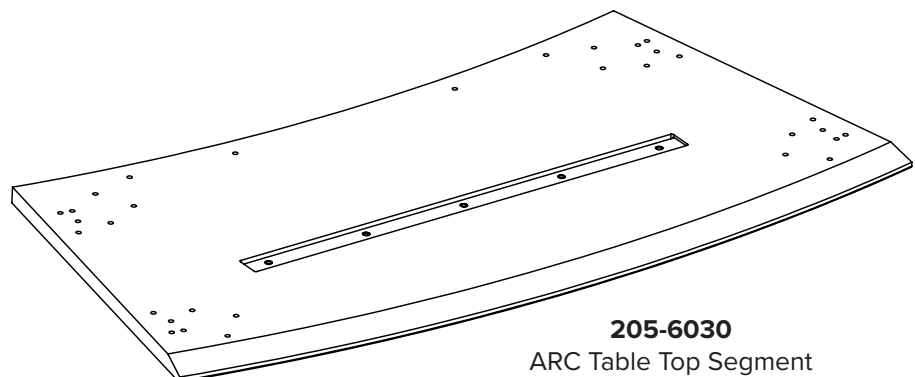

205-6030
ARC Table Top Segment
(Bottom View)

WIRELOOM

Place table leg **(D)** with pre-installed wireloom at desired location. Typically installed in the back side of the table towards the center for wire management to the floor.

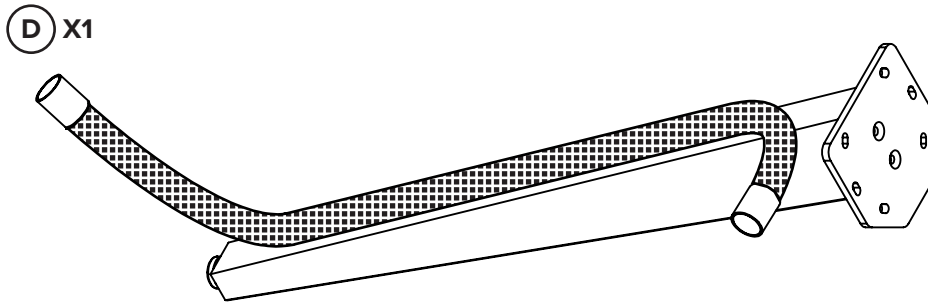

1. Modesty Panel

Attach cable raceway brackets **(E)** to non-grooved side of modesty panel **(G)**. Insert **(A2)** through modesty panel and fasten bracket in place with **(A1)**.

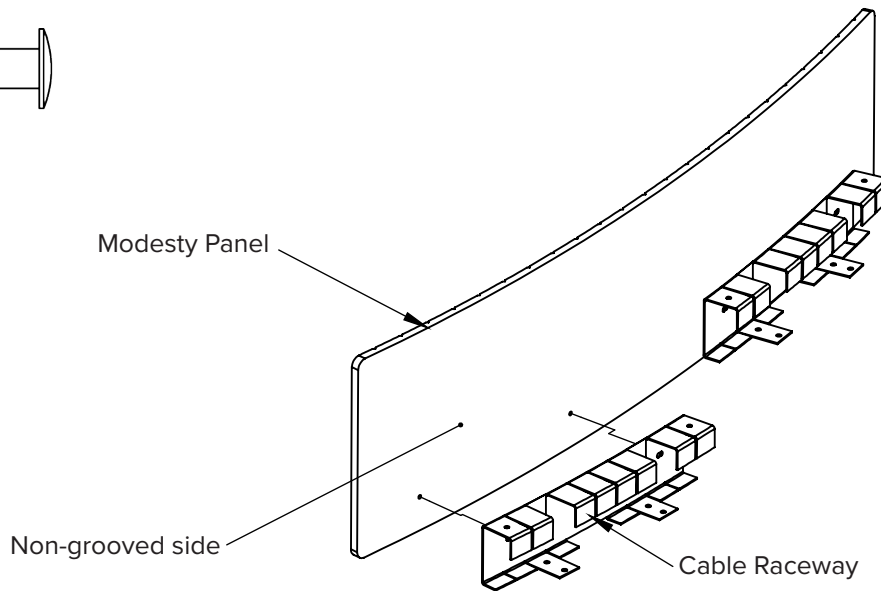

2. Attach Legs

Attach the 4 table legs to the table top using **C** screws per leg in the end mount locations as shown.

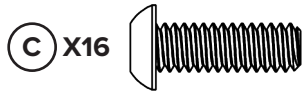

3. Attach Acoustic Panel

Attach the acoustic modesty panel to the table top using **B** screws.

Note: Some flexing of the metal cable raceway may be required to align the mounting holes (closer to bend) with the table inserts.

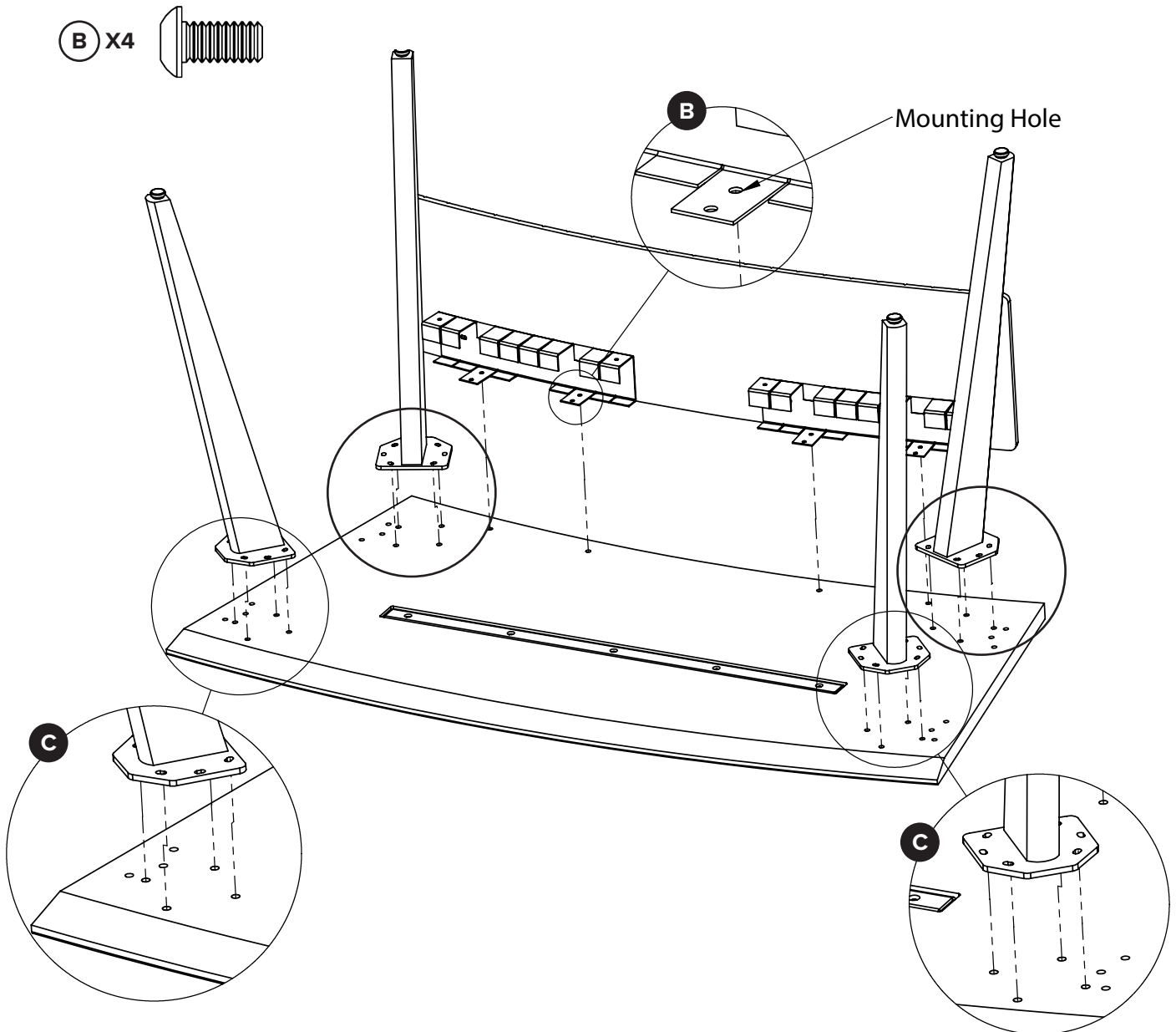

4. Level Table

Position table in the desired location and level if needed using the threaded leveling feet.

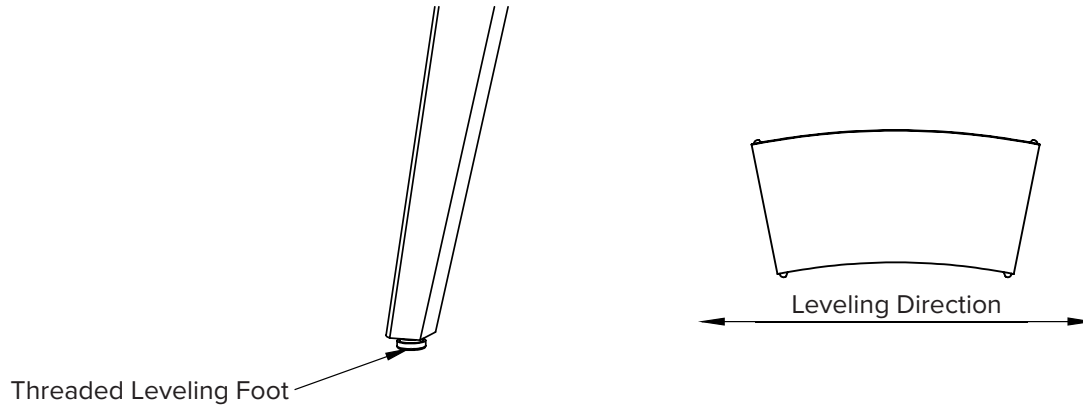

5. Installing Ports

Install ports and chargers into their designated holes in the table top.

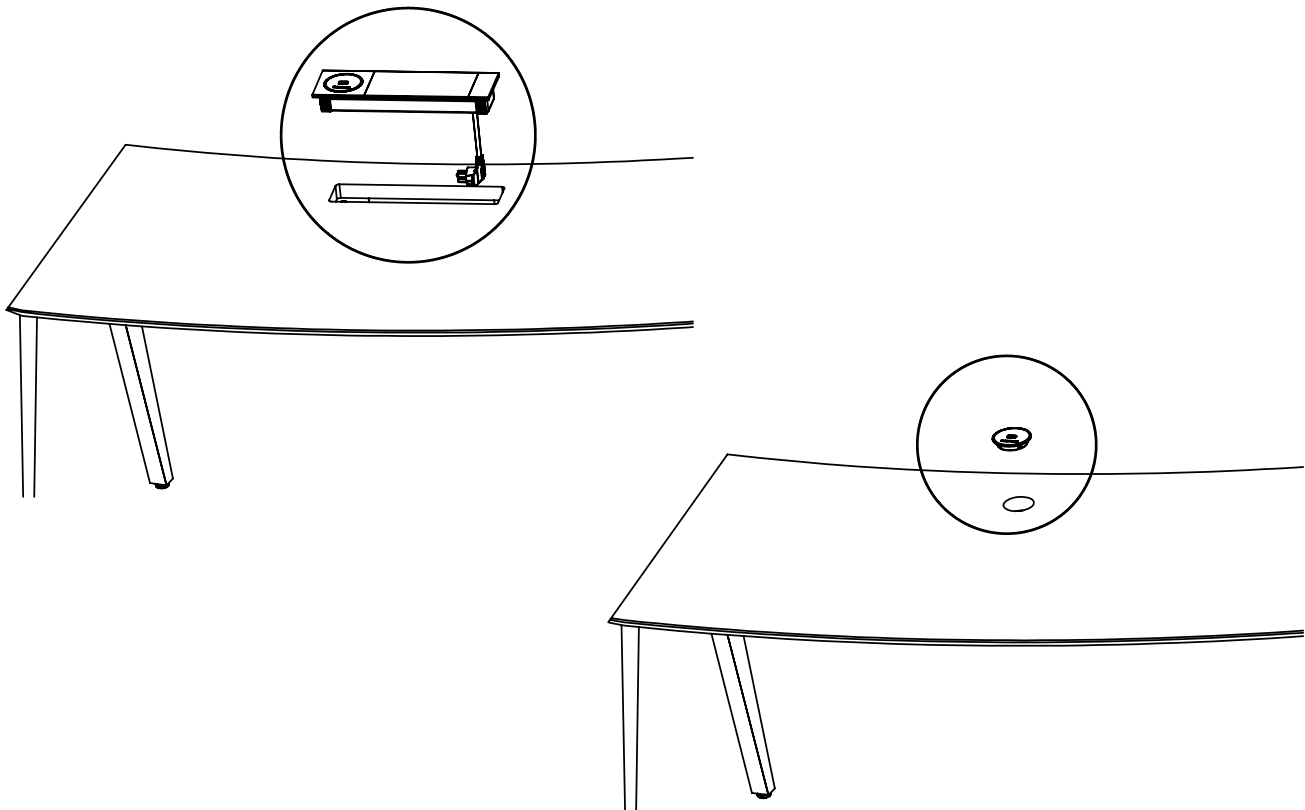

LIMITED WARRANTY FOR COMMERCIAL VIDEO DISPLAY STANDS AND MOUNTS

Salamander is proud to stand behind our products with industry-leading warranties. Should you ever encounter any problem with your Salamander product, let us know. We are here to make it right. 1.800.535.5659 - 860.761.9500

Full warranty including limitations and warranty claim information may be found at www.salamanderdesigns.com/commercial/warranty