

PROPRIETARY INFORMATION: THIS MATERIAL AND THE CONTENTS THEREOF ARE CONSIDERED THE PROPERTY OF SALAMANDER DESIGNS, AND THE DISCLOSURE TO UNAUTHORIZED INDIVIDUALS OR DISSEMINATION, PUBLICATION, OR COPYING THEREOF IS PROHIBITED WITHOUT PRIOR WRITTEN CONSENT BY SALAMANDER DESIGNS OF BLOOMFIELD, CONNECTICUT.

		811 BLUE HILLS AVE. BLOOMFIELD, CT 06002 T/ 860.313.0525 / F/ 860.313.0526		SIZE B
TITLE: SALAMANDER CONFERENCE TABLE TWIN BASE 60 X 72 TRAPEZOID				
MATERIAL		SURFACE TREATMENT		
DRAWN BY G.KESSLER	DATE 8-3-20	HEAT TREATMENT		
ENGINEER	CHECKED BY	SCALE	SHEET	
DRAWING NUMBER		PB320_TM1_T_6072.SLDDRW		1 OF 2 REV

8 7 6 5 4 3 2 1

D
C
B
A

D
C
B
A

PK4
Knife Edge
MDF Core
CARB II Compliant

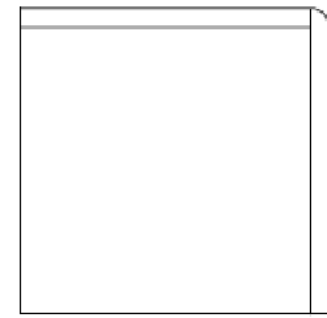
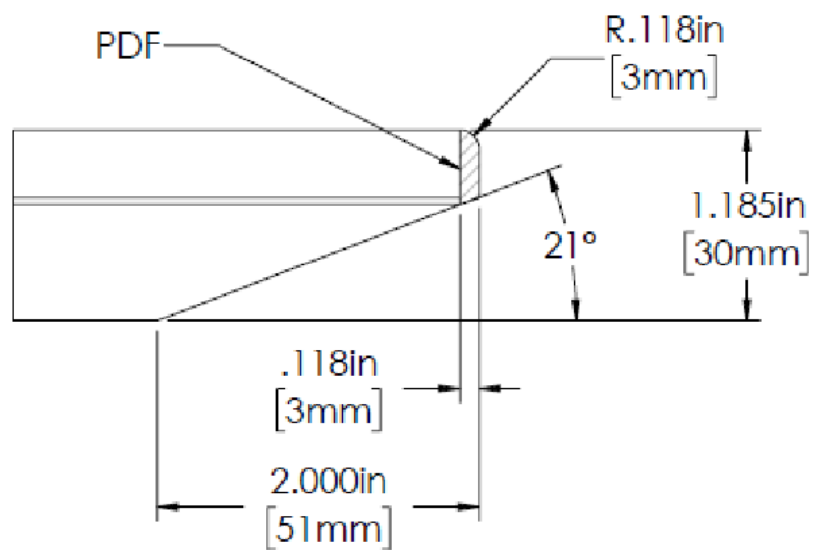

Edge Profile All Sides
Butt Joint
0.0" Radius Outside Corner

WA2
Flat Plywood Edge
Particle Board Core,
45 lb Density,
CARB II Compliant

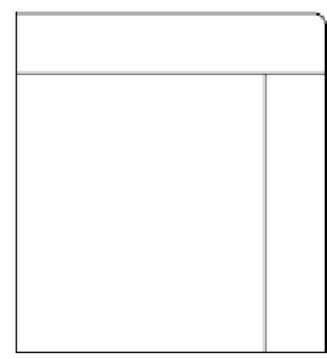
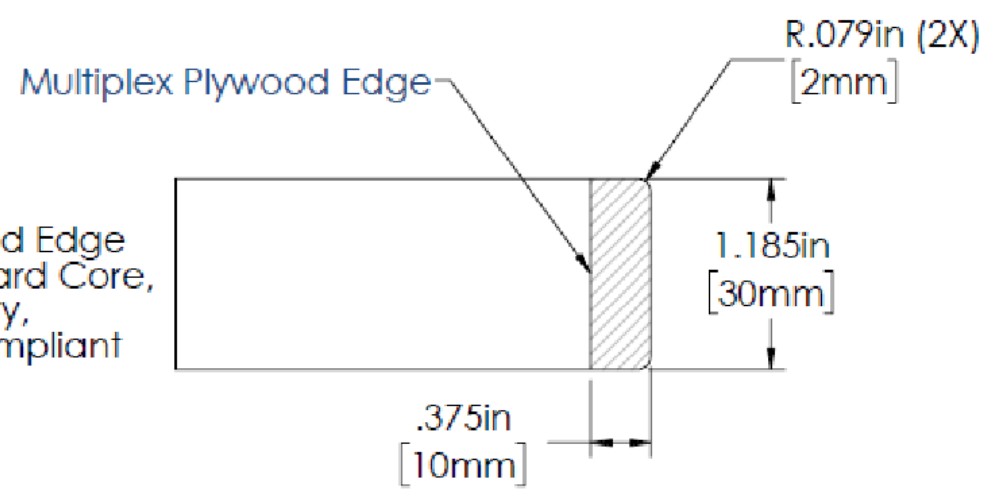

Edge Profile All Sides
Butt Joint
0.0" Radius Outside Corner

		811 BLUE HILLS AVE. BLOOMFIELD, CT 06002 T/ 860.313.0525 / F/ 860.313.0526		SIZE B
TITLE: SALAMANDER CONFERENCE TABLE TWIN BASE 60 X 72 TRAPEZOID				
MATERIAL		SURFACE TREATMENT		
DRAWN BY G.KESSLER	DATE 8-3-20	HEAT TREATMENT		
ENGINEER XXX	CHECKED BY	SCALE XX	SHEET 2 OF 2	
DRAWING NUMBER PB320_TM1_T_6072.SLDDRW				REV XX

PROPRIETARY INFORMATION: THIS MATERIAL AND THE CONTENTS THEREOF ARE CONSIDERED THE PROPERTY OF SALAMANDER DESIGNS, AND THE DISCLOSURE TO UNAUTHORIZED INDIVIDUALS OR DISSEMINATION, PUBLICATION, OR COPYING THEREOF IS PROHIBITED WITHOUT PRIOR WRITTEN CONSENT BY SALAMANDER DESIGNS OF BLOOMFIELD, CONNECTICUT.

8 7 6 5 4 3 2 1