

REVISIONS			
REV.	DESCRIPTION	DATE	APPROVED
1	INITIAL DESIGN	10/31/2020	S. SINGH

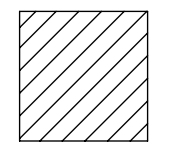
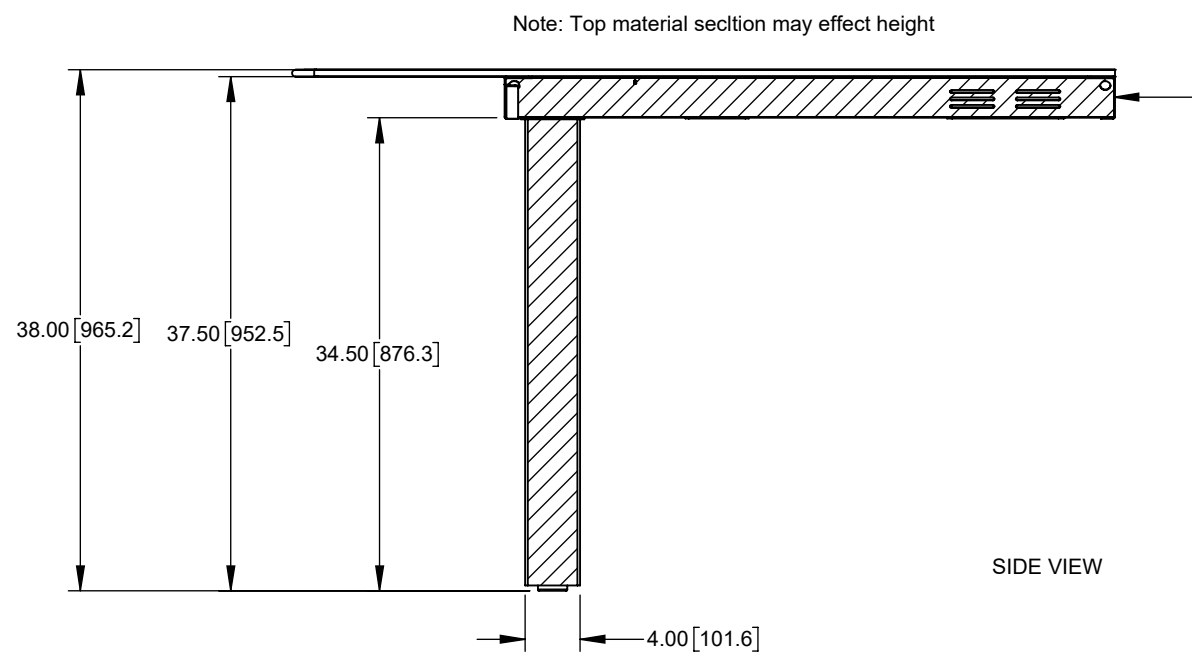
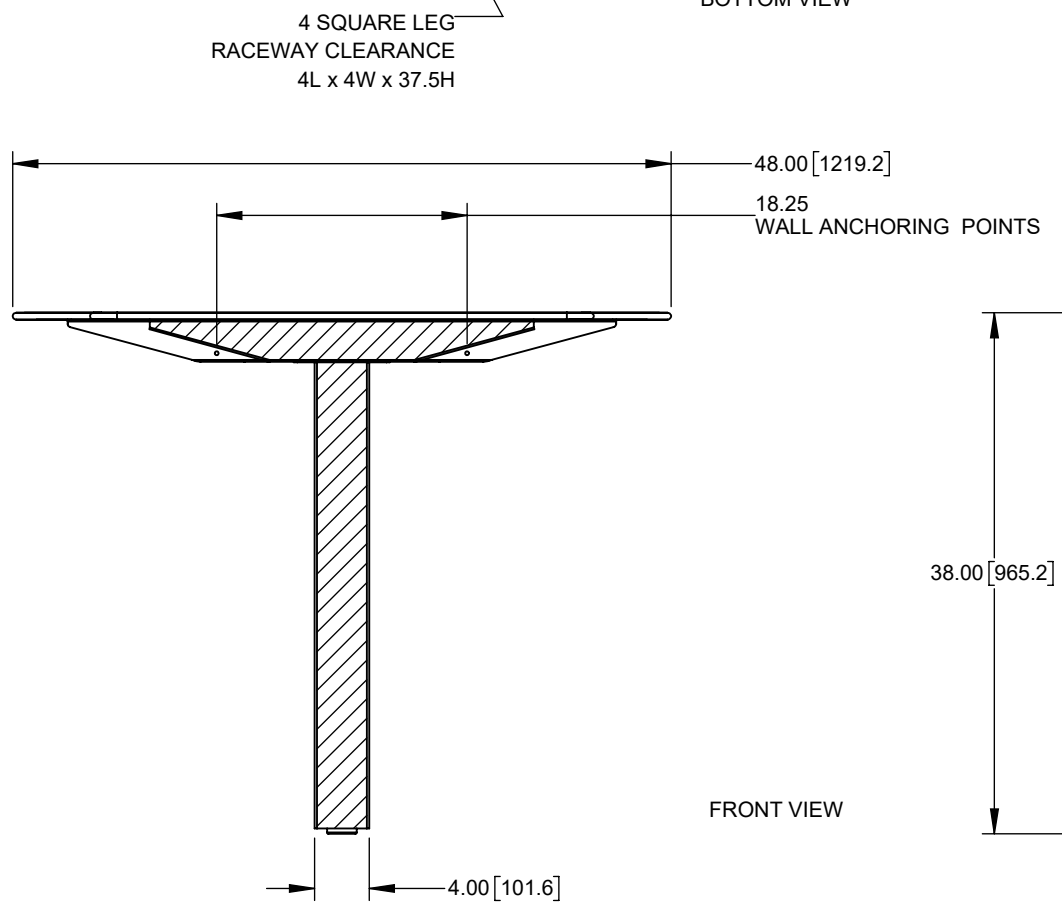
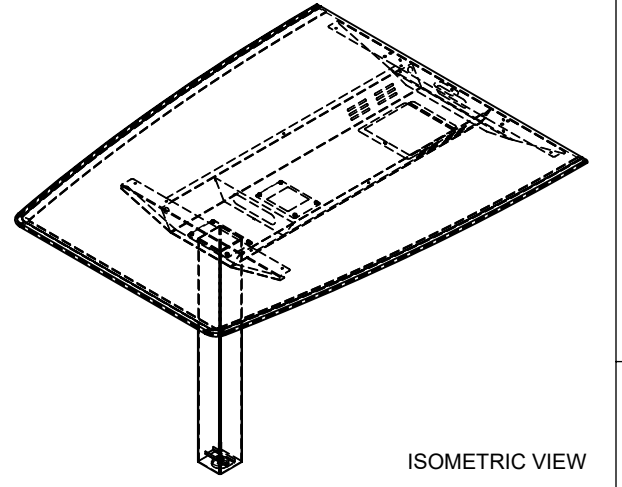
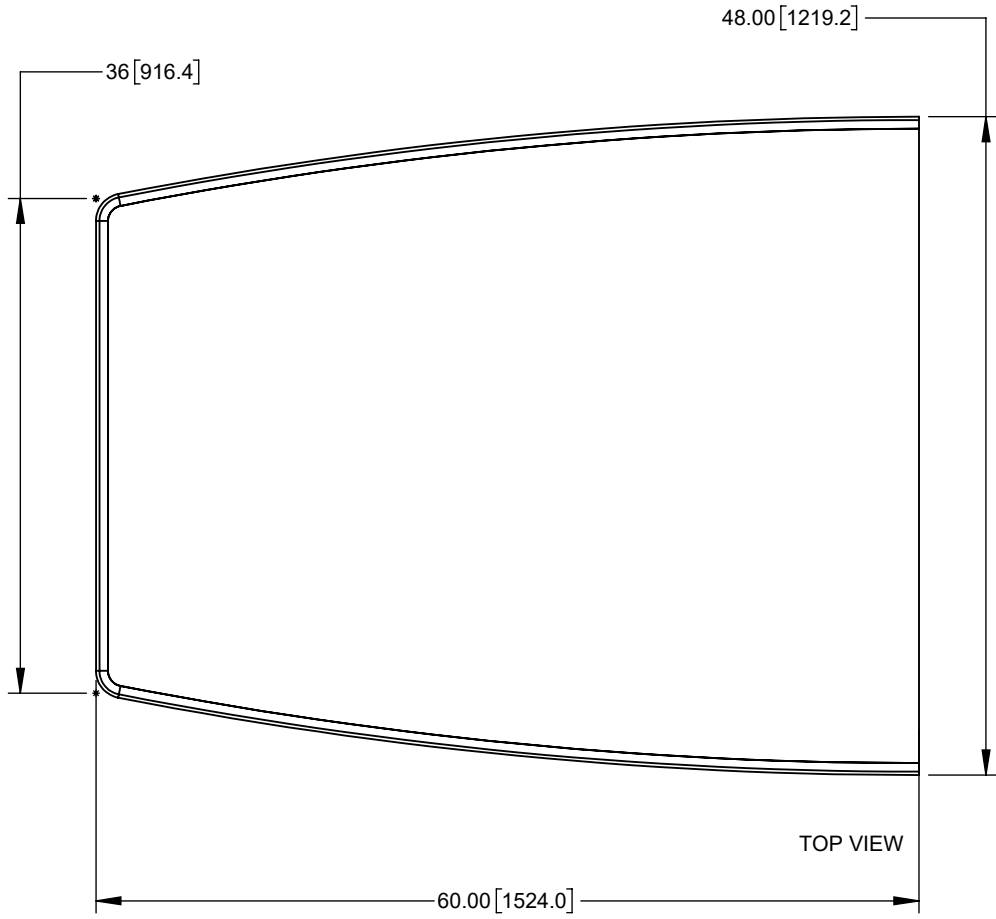
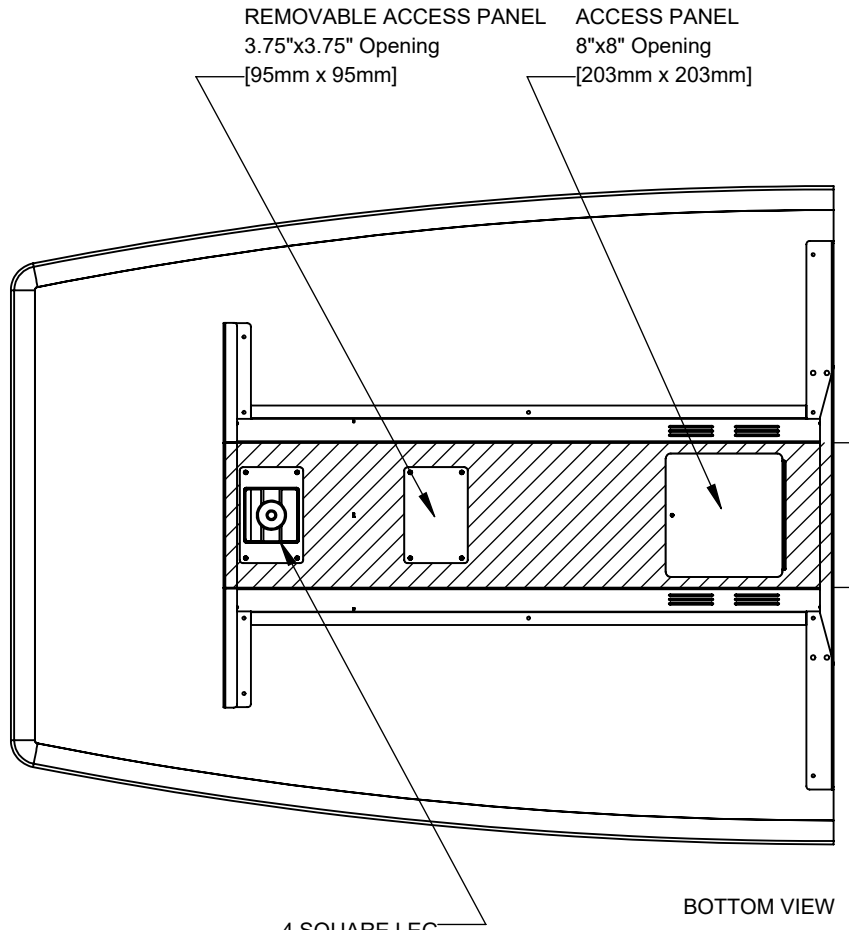

WIRE RACEWAY CLEARANCE

PROPRIETARY INFORMATION: THIS MATERIAL AND THE CONTENTS THEREOF ARE CONSIDERED THE PROPERTY OF SALAMANDER DESIGNS, AND THE DISCLOSURE TO UNAUTHORIZED INDIVIDUALS OR DISSEMINATION, PUBLICATION, OR COPYING THEREOF IS PROHIBITED WITHOUT PRIOR WRITTEN CONSENT BY SALAMANDER DESIGNS OF BLOOMFIELD, CONNECTICUT.

**SALAMANDER DESIGNS** 811 BLUE HILLS AVE. BLOOMFIELD, CT 06002  
T/ 860.313.0525 /F/ 860.313.0526

TITLE: **WALL STATION - COUNTER HEIGHT NO MOUNT**

MATERIAL <i>SEE NOTES</i>	DATE 10/31/2020	SURFACE TREATMENT N/A
DRAWN BY S. SINGH	CHECKED BY	HEAT TREATMENT N/A
ENGINEER	SCALE N/A	SHEET

DRAWING NUMBER TBD	REV 5
-----------------------	----------